

Broquet

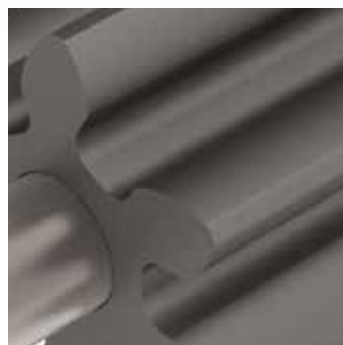

SOLUTIONS FOR THE SUGAR INDUSTRY

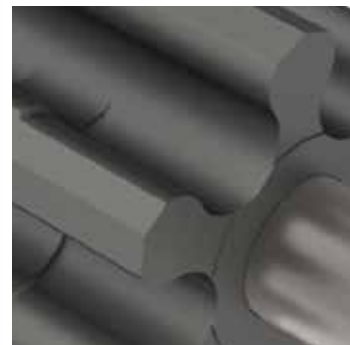

Viscous liquid solutions

40

years of experience to transfer fluids resulting from crystallization, the Broquet pumping solution for high-solid and viscous liquids stands out as one of the best performing and most reliable on the market.

Each of the thousands of installed massecuite and derivatives pumps is the proof of our knowledge of process requirements in sugar mills & refineries.

You will see in following pages pumping solutions for the Sugar Industry, designed by Broquet, the inventor of the genuine gear pump for massecuite and magma.

WE HAVE TECHNICAL SOLUTIONS ADAPTED TO EACH STEP OF THE CRYSTALLIZATION PROCESS.

At every stage of the sugar process, the raw material is transformed and rheological properties of the fluid change. A universal technology could only be an approximation.

For optimum performance, Broquet offers a complete range of rotors adapted to the different states of the liquid



MC ROTOR

Designed for massecuite and magma, it is the famous design throughout the sugar manufacturing world. It carries massecuite without denaturing the geometry of sugar crystals.

An ingenious exhaust system, a low-contact gear mesh and a scraping profile enable to preserve the particles present in the mother liquor.

APPLICATIONS

- Beet and cane processing
- White, raw and AP massecuite
- Any magmas
- Continuous vacuum processing

MAIN BENEFITS

- Prevention of crystal damage
- Low pulsation, low emulsification
- Very high suction power
- Totally reversible in operation
- Versions for high brix or low viscosity



X ROTOR

Recommended for the transfer of semi-viscous liquids, the innovative profile with heavy relief and its 6-tooth architecture endow it with economical hydraulic performance and high delivery for a more compact pump.

It can be used on solutions that are slightly or accidentally loaded with crystals.

APPLICATIONS

- High/low greens
- Affination and wash syrups/liquors
- Hot molasses

MAIN BENEFITS

- Tolerates the possible presence of crystals
- Less pulsation
- Low sensitivity to viscosity variations
- Economical operation



B ROTOR

Developed to pump viscous to very viscous fluids, its tooth profile enables an exceptional suction power even at the lowest rotation speeds.

It is a very effective in cold to very cold molasses or syrup loading/unloading operations and this rotor is often used on particularly difficult process applications.

APPLICATIONS

- Cold molasses/syrups
- Accidentally loaded liquids
- Very viscous fluids

MAIN BENEFITS

- High suction power at low speed
- High tolerance of the presence of crystals
- Totally reversible in operation



RELIABLE & COMPACT DESIGN

DESIGN LAYOUT

- Few rotating elements
- 4 internal bushings sets
- No cantilever arrangement
- No synchronizing gearbox
- No scraper

LAYOUT

- Eco-design
- Optimum dimensions for high capacities
- Built-in ports

8 MAJOR COMPONENTS ONLY

ROTORS

The 6-tooth architecture of the gearing ensures to constantly have 6 internal sealing points. This is 2 to 3 times more than in most other technologies.

- High suction power
- Suited to continuous vacuum processing
- Less pulsation

BUSHINGS

For ease of maintenance, the pump is equipped with static bushings in covers and dynamic sleeves on shafts.

Bushings are lubricated by the pumped liquid.

Thanks to many years of experience and research, these important components are manufactured from noble materials with very accurate tolerances to guarantee a long lifetime and tolerate possible degraded operating modes of the pump.

- No external lubrication
- No pollution hazard
- Simple

DYNAMIC SEAL

Only the shaft of the leading rotor is sealed using soft gland-packing as standard.

Pumps can be delivered with various brands of single or double mechanical sealing.

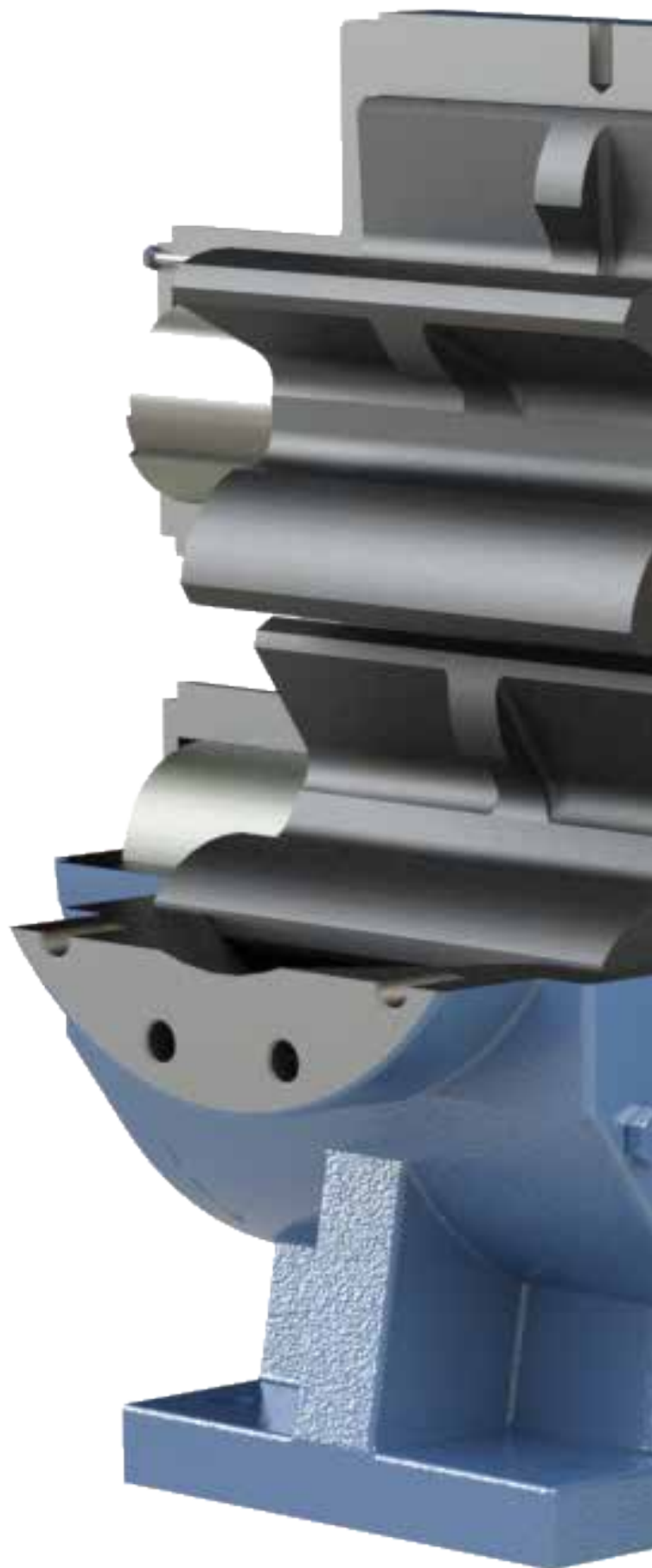

 **ONLY BROQUET GENUINE PARTS ENSURE THE RELIABILITY OF YOUR PROCESS**

EASY OPERATING & MAINTENANCE

WORKING PRINCIPLE

As rotor teeth disengage, the liquid is pumped into the tooth, then carried along the outside of the gearing without passing through the central meshing area.

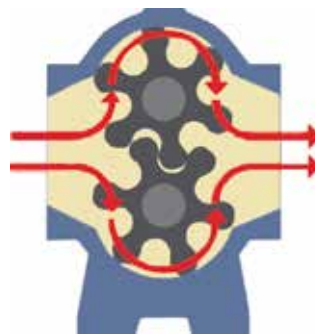

DESIGNED FOR THE SUGAR PROCESS

During operation, the pump can run alternatively in both direction to avoid piping plug up. If necessary, the media can be remelt thanks to several built-in connections

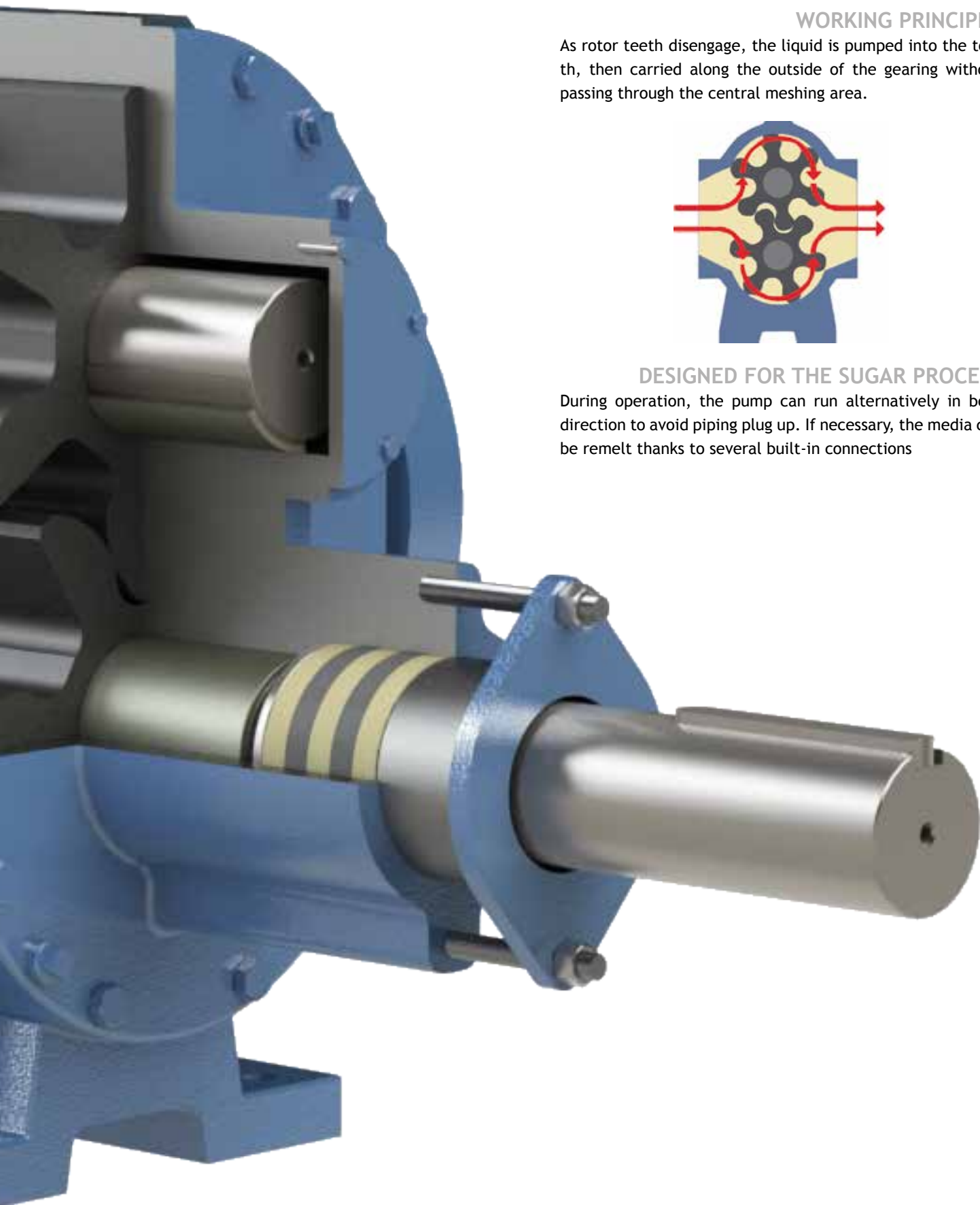

SELECTION DIAGRAM

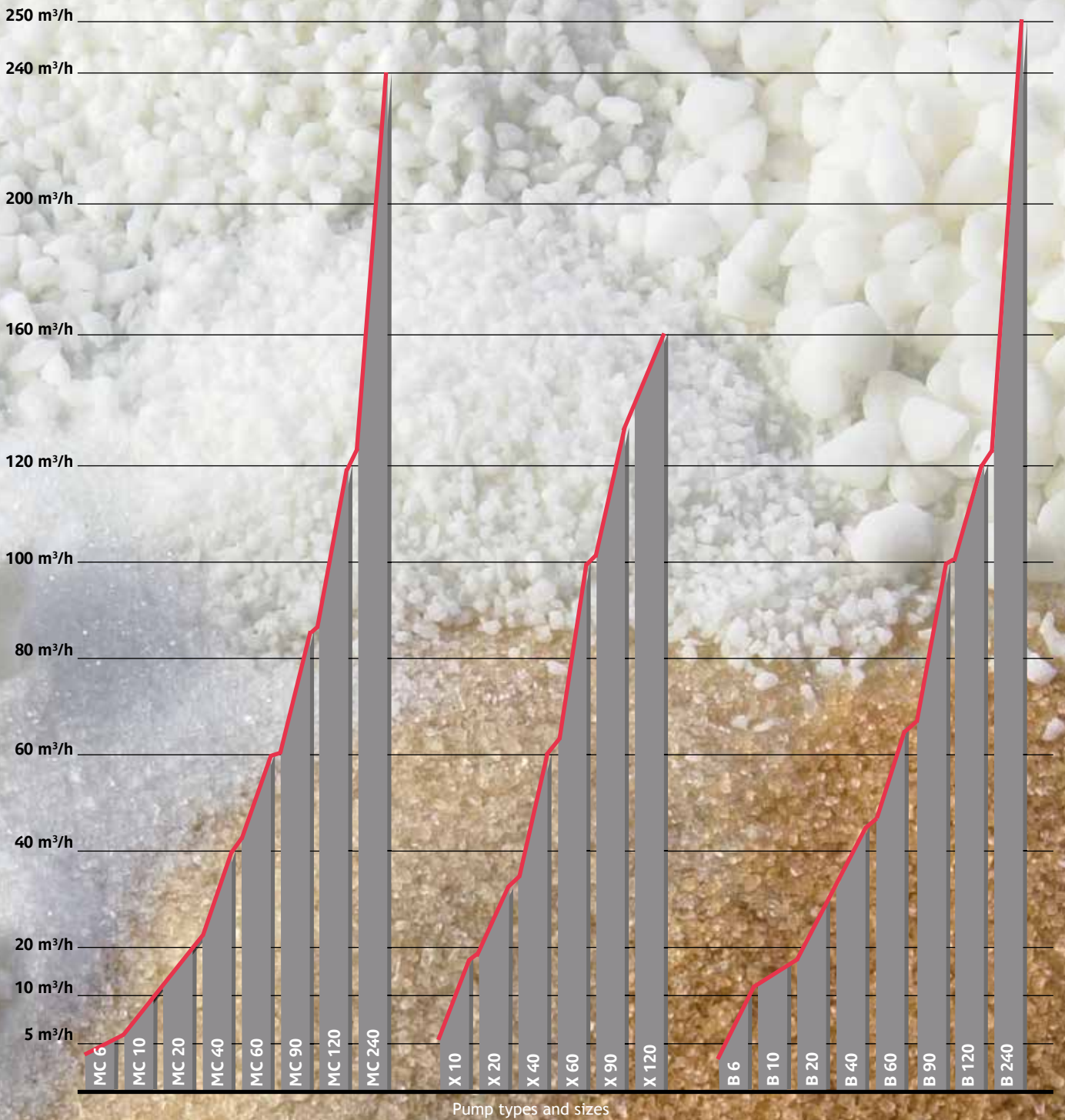

Contact us to select the right pump for your application



MC ROTOR



X ROTOR



B ROTOR

MAIN VERSIONS

OPTIONS

CAST IRON PUMP



EXTENDED LIFETIME BUSHINGS

- Ceramic based material (hardness 1200 HV)
- Adapted to basic/acid liquids
- Better wear resistance



DIMENSIONS

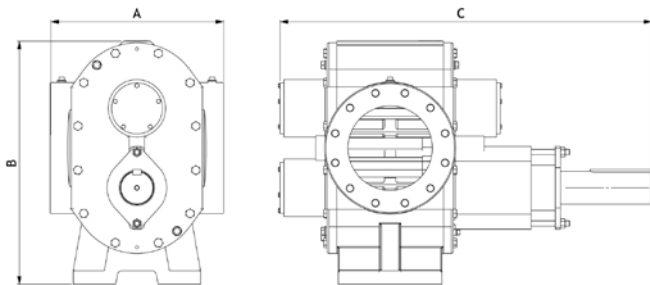

Size	A	B	C	Ports	Ports	Weight
	mm	mm	mm	ISO PN16	ANSI 150 Lbs	kg
10	292	353	555	DN100	4"	105
20	284	438	733	DN125	5"	180
40	350	555	867	DN150	6"	290
60	450	630	967	DN200	8"	430
90	547	678	1098	DN250	10"	650
120	778	773	1120	DN250	10"	920
240	778	773	1510	DN300	12"	1600

FULL STAINLESS STEEL PUMP

Up to size 60, pumps can be delivered with body and rotors in stainless steel



HEATING JACKET

Pumps can be assembled with integral heating jacketed body (Version B).
Can be used with hot water, steam or thermal oil.



SAFETY AND INSTRUMENTATION

- Internal relief by-pass
- External safety valve
- Sensors (T°, pressure, flow rate)
- Safety filters to catch unexpected solid ingredients





PREFERRED SOLUTION WORLDWIDE

- A technical solution that is operational in more than 60 countries
- A network of partners, distributors and agents throughout the world

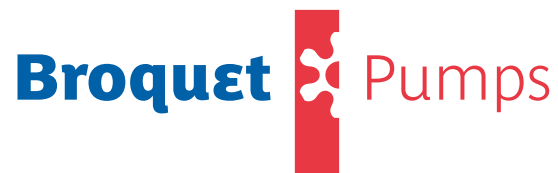

+33 (0)1 39 47 36 11 T
+33 (0)1 39 47 36 19 F

broquetpumps.com
info@broquetpumps.com

Georges Brière s.a. Manufacturer
15, rue Jean Poulmarch
95100 Argenteuil, France